

45 Litre Electric Mini Oven Double Hot Plates White



IG7145

PO Number:

Please read these instructions carefully before use and retain for future reference

**Before switching on your appliance,
always check for any damage which may have been caused in transit**

CONTENTS

Important safety instructions	2-4
Specifications.....	4
Appliance Overview	4
Operating instructions.....	5-6
Cleaning & Maintenance.....	7
Fuse Replacement.....	7
Troubleshooting.....	8
Disclaimer	8
Disposal Information.....	9
Igenix Warranty	10-11

IMPORTANT SAFETY INSTRUCTIONS

Important: Read all instructions before using the appliance.

1. This appliance is for domestic use only. This appliance is for indoor use only. Do not use outdoors.
2. This appliance should only be used by adults.
3. This appliance is not intended for use by persons (including children) with reduced physical, sensory or mental capabilities, or lack experience and knowledge.
4. Cleaning and user maintenance shall not be made by children. Keep the appliance and its cord out of reach of children. Children shall not play with the appliance.
5. Never leave this mini oven unattended when in use.
6. Make sure the voltage in your home corresponds to the one shown on the rating label of the appliance.
7. Use this appliance only for its intended use as described in this manual. Do not use corrosive chemicals or vapors in this appliance.
8. Never touch hot surfaces with your bare hands. Always use insulated oven gloves when removing hot items from the oven. Always use the appropriate handles and dials.
9. Do not operate this appliance if it has a damaged cord or plug, if it is not working properly or if it has been damaged or dropped. If the supply cord is damaged, it must be replaced by the manufacturer or its service agent or a similarly qualified person in order to avoid a hazard.

10. To protect against electric shock, do not immerse cord, plug or any parts of the oven in water or any other liquid.
11. Do not let cord hang over edge of table or counter, or touch hot surfaces.
12. Use only the accessories provided with the mini oven.
13. Do not place on or near an electric or gas hob.
14. Allow at least four inches of spaces around each side of the mini oven for adequate air circulation.
15. To disconnect, turn all controls and switches to the 'OFF' position. Remove the plug from the power socket. Do not pull the plug by its cord.
16. Unplug from the socket when not in use or before cleaning.
17. Allow the oven to cool down before removing parts or cleaning. Do not clean with metal scouring pads as this may create a risk of electric shock.
18. To disconnect, turn the timer control dial to the 'OFF' position and then remove the plug. Always hold the plug and never pull the cord.
19. Do not insert any oversized foods, containers or metal utensils inside the cavity as this may create a risk of fire.
20. A fire may be caused if the mini oven is covered by or touching flammable materials such as curtains, tea towels, paper towels or oven gloves etc. Do not store any flammable items on or near the mini oven.
21. Only use oven safe utensils and bake ware on or inside the oven.
22. Extreme caution must be taken when removing any containers with hot oils or liquids.
23. Do not cover any parts of the mini oven or baking trays with metal foil as this may cause the oven to overheat.
24. Do not use the cavity for storage purposes. Do not leave cooking utensils or food in the cavity when not in use.
25. Do not place any of the following materials in the oven: cardboard, plastic, paper or anything similar.

26. Extreme caution should be exercised when using cooking or baking containers constructed of anything other than metal or ovenproof glass.
26. Be sure that nothing touches the top or bottom elements of the oven.
27. Cooking utensils may become hot because of heat transferred from the food. Pot holders may be needed to handle the utensil.
28. **WARNING:** It is hazardous for anyone other than a trained person to carry out any service or repair.
29. This appliance is fitted with a tempered safety glass door. Tempered glass can still break around the edges. Avoid scratching glass surface or edges.

SPECIFICATIONS

Supply Voltage:	220-240V, 50-60Hz
Max Output:	1600W
Hotplate Output Left / Right	1000W / 600W
Oven Output	1600W
Oven Capacity:	45 Litres

APPLIANCE OVERVIEW

- A: Housing
- B: Control panel
- C: Oven temperature knob
- D: Power indicator light
- E: Left plate control knob
- F: Right plate control knob
- G: Oven function knob
- H: Oven foot
- I: Door handle
- J: Upper door frame
- K: Lower door frame
- L: Tray handle
- M: Bake tray
- N: Wire rack
- O: Left plate
- P: Right plate

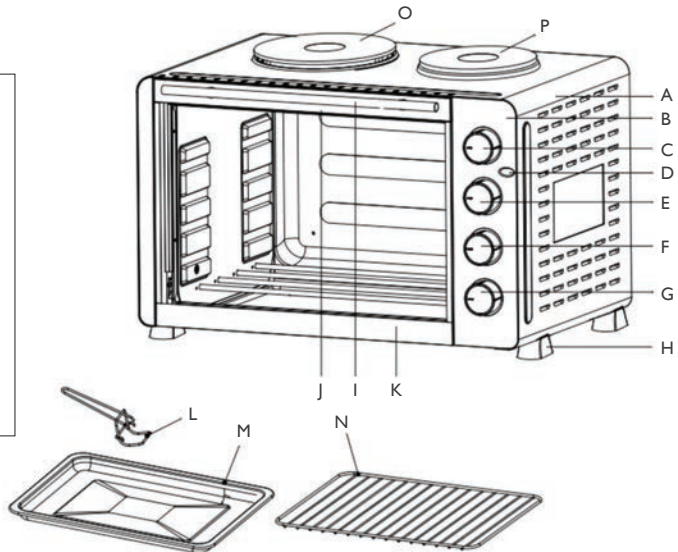



OPERATING INSTRUCTIONS

This product is intended for domestic household use only

- When using the oven for the first time, be sure to:
- Read all the instructions included in this manual.
- Checked that the oven is unplugged and all the switches and control dials are turned to the 'OFF' position.
- Remove all wire racks, baking trays and accessories and wash thoroughly in hot soapy water or in the dishwasher. Dry and re-assemble in the oven.
- Plug the oven into the socket making sure the voltage in your home matches that of the mini oven.
- Turn the oven on at full heat for 15-20 minutes to eliminate any liquids that may have remained after cleaning.
- A small amount of smoke may be emitted during first use. This should disappear within 15-20 minutes.
- Oven Temperature Control (Dial C): Temperature variable from 100°C to 230°C.
- Left Hotplate Control (Dial E): Choice of 3 power settings, level 1, 2 or Max.
- Right Hotplate Control (Dial F): Choice of 3 power settings, level 1, 2 or Max.
- Function Selector (Dial G): There are 3 element settings:

Grill  Only upper heating elements work. Suitable for grilling.

Bake  Only lower heating elements work. Suitable for baking.

Roast  Both the upper & lower heating elements work together. Suitable for roasting.

Power Indicator Light (Fig. D): This will be illuminated whenever the appliance is switched on.

Baking Tray: For use in grilling and roasting. This can also be used as a drip pan.

Wire Rack: For toasting, baking, and general cooking.

Tray Handle: Allows you to pick up the wire rack, and bake tray when they are hot.

WARNING: TO AVOID RISK OF INJURY OR BURNS, DO NOT TOUCH HOT SURFACES WHEN OVEN IS IN USE. ALWAYS USE INSULATED OVEN GLOVES WHEN REMOVING HOT ITEMS FROM THE OVEN.

USING YOUR MINI OVEN TO GRILL

Please note that the grill function uses only the upper heating elements. For best results, it is recommended that you preheat the oven for 15 minutes on 220°C.

1. Food should be placed as close as possible to the top heating element without touching it.
2. Set temperature control to desired temperature.
3. Turn function selector (Dial G) to grill .
4. Turn food over midway through prescribed cooking time.
5. When grilling is complete turn the function selector to 'OFF'

USING YOUR MINI OVEN TO BAKE

Please note that the baking function uses only the bottom heating elements. For best results, it is recommended that you preheat the oven for 15 minutes on 220°C.

1. Set temperature control to appropriate temperature.
2. Turn function selector (Dial G) to bake .
3. Place the wire rack on the lowest or middle support.
4. Place food on the wire rack.
5. Food should be placed as close as possible to the lower heating element without touching it.
6. When baking is complete turn the function selector to 'OFF'

USING YOUR MINI OVEN TO ROAST

This oven can cook up to a 3.6kgs chicken/ roasting joint.

For best results we recommend that you preheat the oven for 15 minutes on 220°C. We do not recommend the use of oven roasting bags or glass containers in the oven. Never use plastic, cardboard, paper or anything similar in the oven.

1. Place the wire rack in the oven at the lowest position
2. Place food to be cooked in a suitable roasting pan. If you wish to use the baking tray, then you do not need to insert the wire rack because the bake tray supports itself on the oven support guides.
3. Set temperature control to appropriate temperature.
4. Turn function selector (Dial G) to roast .
5. When cooking is complete, turn the function selector to 'OFF'.

USING YOUR HOTPLATES

Power Level Guide

Power level 1: For simmering or slow cooking.

Power level 2: For shallow frying of meat and pan dishes.

Max: For rapid heat or boiling water.

Left Hotplate

1. Place pan onto the hotplate. It should have a solid base which is as even as possible and the diameter should be the same size as the hotplate.
2. Turn the left hotplate dial to desired power level (1, 2 or MAX)
3. When cooking is completed, turn the left hotplate dial to the "OFF" position.

Right Hotplate

1. Place pan onto the hotplate. It should have a solid base which is as even as possible and the diameter should be the same size as the hotplate.
2. Turn the right hotplate dial to desired power level (1, 2 or MAX).
3. When cooking is completed, turn the right hotplate knob to the "OFF" position.



The oven cannot be operated simultaneously with either hotplate. Do not operate hotplates simultaneously with the oven.



WARNING: Do not leave the hotplates switched on without any cooking pans in place. This will damage the appliance, discolouring the top of the appliance. Plus excessive heat build-up. The same will happen if you use a singular large pan on both hotplates at the same time.

CLEANING & MAINTENANCE

The oven should be cleaned regularly and any food deposits removed to prevent an accumulation of grease and to avoid unpleasant odours. Failure to maintain the oven in a clean condition could lead to deterioration of the surface that could adversely affect the life of the appliance and possibly result in a hazardous situation.

1. Turn off the mini oven and remove the power plug from the wall socket before cleaning. Allow to cool.
2. Do not immerse the mini oven or power supply in water or wash under the tap.
3. Remove the wire shelf and baking tray and wash in hot soapy water.
4. Clean the outside of the mini oven with a damp cloth or sponge.
5. Do not use any abrasive cleaners or sharp utensils to clean the mini oven as these may scratch the surface and weaken it.
6. Dry all parts thoroughly before replacing inside the oven.

Your oven features a continuous clean coating that automatically cleans itself during normal operation. Any spattering that occurs while cooking and comes into contact with the continuous coating is oxidized while the oven is in operation. If desired, wipe the walls with a damp sponge, cloth or nylon scouring pad and mild detergent.



Do not use steel wool scouring pads, abrasive cleaner or scratch the oven surface with a metal utensil.

MAINS PLUG FUSE REPLACEMENT

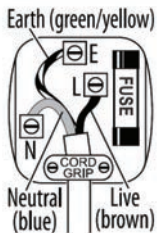

Fuse Replacement (Class I)

This appliance must be earthed. Remove the central screw on the plug and open the shell. Take out the fuse and replace with a new fuse of the same Amp. Install the shell again and tighten the screws.

TROUBLESHOOTING

Problem	Possible Cause	Solution
The mini oven does not work.	1. Not properly plugged into the mains wall socket. 2. No electricity in the mains wall socket.	1. Plug in firmly 2. Check fuse or breaker. 3. Check all settings according to this manual.
Smoke and a slight odour coming from the mini oven.	1. Excess lubricants used in the manufacturing process.	1. This is normal and the smoke and smell will cease after a short period of time.
Grill is not working.	1. Top elements are not turned on.	1. Turn dial G to the  position.
Condensation on the wall at the rear of the mini oven.	1. Water evaporating from foods with a high water content e.g. frozen chips, roast chicken etc.	1. It is completely normal for this to happen and when the oven has cooled the excess moisture can be wiped off.
Cooking fat is splattering.	1. Grill is set too high. 2. Shelf is too close to the grill.	1. Reduce the temperature of the grill. 2. Position the shelf lower in the oven.

DISCLAIMER

Updates to hardware components are made regularly. Therefore some of the instructions, specifications and pictures in this documentation may differ slightly from your particular situation. All items described in this guide are for illustration purposes only and may not apply to your particular situation. No legal right or entitlements may be obtained from the description made in this manual.

DISPOSAL INFORMATION

The European Directive 2012/19/EU on Waste Electrical and Electronic Equipment (WEEE), requires that old household electrical appliances must not be disposed of in normal unsorted municipal waste.



Old appliances must be collected separately in order to optimise the recovery and recycling of the materials they contain and reduce the impact on human health and the environment.

The crossed out “wheeled bin” symbol on the product reminds you of your obligation, that when you dispose of the appliance it must be separately collected. Consumers should contact their local authority or retailer for information concerning the correct disposal of their old appliance.



Igenix Warranty Terms & Conditions

This product is guaranteed for a period of 12 months as standard from the date of purchase against mechanical and electrical defects. You can extend your warranty for a further 12 months by registering your product.

Upon registration we will cover your product for a period of 24 months from the original purchase date against any mechanical or electrical defects.

To qualify for the guarantee, the product must be used for domestic household use only and in accordance with the instructions in the user manual. Any misuse of the product will result in the warranty being void.

The guarantee does not cover accidental damage, misuse, neglect, tampering or incorrect adjustment or installation.

The guarantee will be rendered invalid if the product is resold, has had its serial number removed (or has an invalid serial number), or if an unauthorised person has carried out any repairs or alterations.

The warranty does not cover accessories or consumable parts that require replacement under normal use. This includes shelving, dials, filters, belts and trays etc.

In the unlikely event of a breakdown please refer to the Troubleshooting guide in your user manual and check all plugs, fuses and the electricity supply.

If you still require assistance please contact our Customer Service department on **01473 271 272** or write to us at the following address:

**Customer Service Department
38 Bluestem Road, Ransomes Europark
Ipswich, IP3 9RR**

Please quote the Product Code which begins 'IG' or 'DF' and the PO Number on the front of the instruction manual and give details of the exact fault. We will then decide whether to repair or replace the item.

Before we arrange the repair or replacement you will be required to return a copy of your proof of purchase. Please retain your original.

If an item is replaced within the agreed guarantee period, the guarantee for the replacement item will be calculated from the purchase date of the original.

In the event that the product is inspected and no fault is found or the product is not within the guarantee period you will be charged for the repair and any carriage costs.



Thank you for choosing Igenix

As a valued customer we would like to offer you a FREE 2 year warranty to cover your product against any electrical or mechanical defects.

This means that in the unlikely event you develop a fault or problem with your product we will happily repair or replace the item free of charge.

To qualify for the 2 year warranty you must register your product within 30 days of purchase. The full Terms & Conditions of our warranty policy are shown on the opposite page. They are also available on our website. **www.igenix.co.uk**

igenix

38 Bluestem Road, Ransomes Europark, Ipswich, IP3 9RR

Tel. 01473 271 272

Disclaimer: Igenix operate a policy of continual improvement and development.
We therefore reserve the right to change/alter the specification and appearance of our appliances without prior notice.
All diagrams and images shown in this manual are for illustration purposes only.